

# AVi160T

---

12 Volt, 230 Amp

T-Mount for Ford and Navistar



Pulleys are for illustrative purposes only, and are not included.

# More Power For Demanding Applications

Leece-Neville AVi160 T-mount alternators have been designed specifically for Ford and Navistar vehicles, including E and F Series truck and van, and CityStar and LCF medium duty truck applications.

The AVi160 is a 160 mm unit that provides **230** amps of total power, and over 130 amps at typical diesel engine idle speeds.

Designed for both diesel and gasoline engines, the AVi160T is a true high temperature alternator, and will not shut down when things start getting a little hot.



Leece-Neville is proud to manufacture product in the USA.

## Output

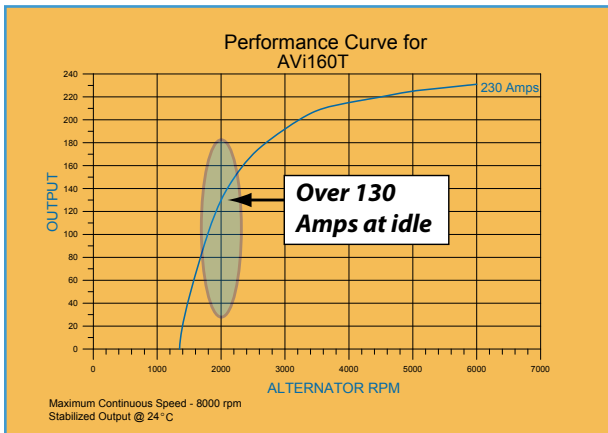

## Dimensions

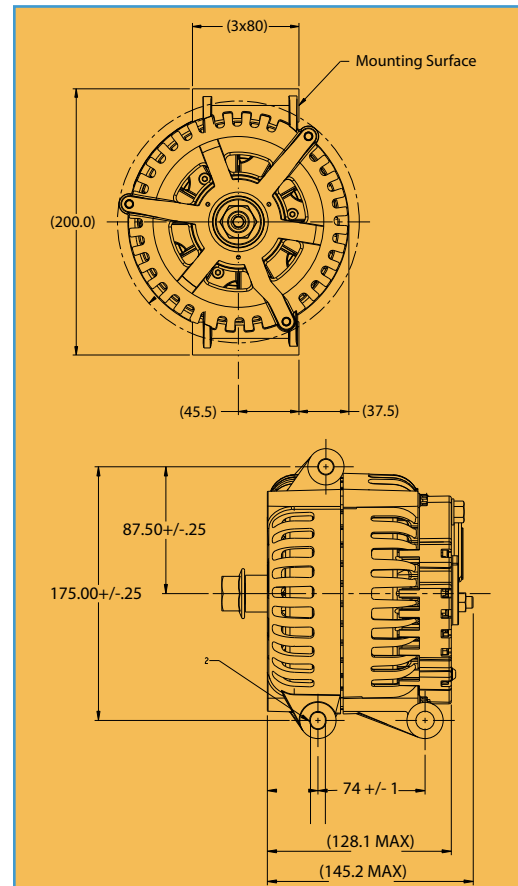

## AVi160T Specifications

Performance	12 volt, 230 amps 130 amps at idle
Temperature limits	-40° C to 125° C
Maximum speed	12,000 RPM continuous 14,000 RPM intermittent

## Features / Benefits

- High Temperature rated to 125°C
- No throttle-back regulator, maintains output at high temperatures
- Case Ground
- Bi-directional rotation
- Welded diode / lead frame connections (no solder)
- Required mounting hardware and harnesses are included

## Installation configurations

Sales Number	Regulator	Application	Notes
A160201-1	PCM	<ul style="list-style-type: none"> <li>• For all 2008 and newer F series trucks (except 6.0 L diesel).</li> <li>• For 2010 and newer 6.2 L Ford gasoline engines</li> </ul>	Ford 6G. Package includes extended mounting bolts (required). No adapter harness is necessary
A160202-2	I-Line	<ul style="list-style-type: none"> <li>• Pre-2008 F and E series trucks and vans.</li> <li>• All 6.2 L Ford diesel engines</li> </ul>	Ford 3G, 4G, 6G. Package includes wiring harness and extended mounting bolts (required). See adapter harness detail below
A160202-3	I-Line	<ul style="list-style-type: none"> <li>• Navistar CityStar</li> <li>• Ford / Navistar LCF</li> </ul>	Package includes extended mounting bolts, spacer and washers (required). No adapter harness is necessary

### AVi160 I-Line connection and adaptor harness

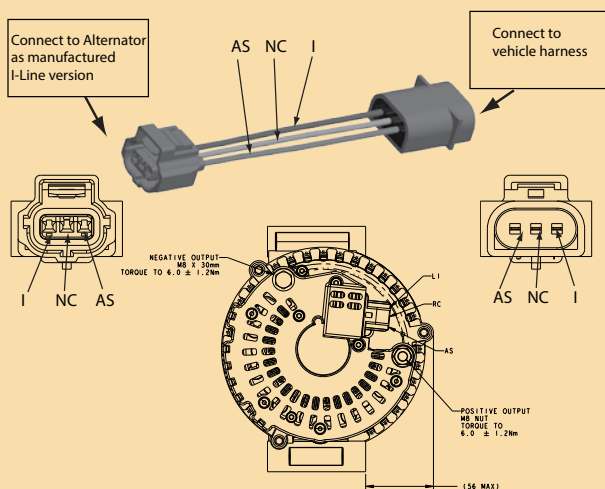

See TSB-1142 for installation procedure.

Individual components provided with alternators are also sold separately- see SP1027 service parts list on our website.

NOTE: When increasing the size/output of an alternator, vehicle's cabling must be reviewed to determine adequate size.

Extended mounting bolts **included** with all A160201-1



Wiring harness and bolts **included** with all A160202-2



Extended mounting bolts, spacer, washer **included** with all A160202-3



## Ford Applications For The A160201-1 and A160202-2

Diesel	Vehicle	Year Models	O.E Alternator #	Type	Motorcraft Alternator #	Lester #
6.0L	E-Series	2004 - 2006	5C2T-10300-CA 5C2Z-10346-CA	6G	GL649	8445
6.0L	F-250 & F350	2003 - 2007	6C3Z-10346-BA	6G	GL643 GL647	8478
6.0L	E-350	2004 - 2005	6C3Z-10346-BA	6G	GL643	8478
6.0L	F-250 & F350	2005 - 2007	6C3Z-10346-DA	6G	GL644	8479
6.0L	Excursion	2005	6C3Z-10346-DA	6G	GL644	8479
6.0L	E-350	2005 - 2007	6C2Z-10346-CA	6G	GL630	
6.0L	E-350	2004 - 2007	6C2Z-10346-EA	6G	GL635	8477
6.0L	F 250 & F350	2003 - 2006	6C2Z-10346-EA	6G	GL635	8477
6.0L	F-250 & 350	2006	5C3Z-10346-DA	6G	GL648	8476
6.0L	F-250	2005	4C3T-10300-AA	6G	GL569 GL557	8306
6.0L	Ford Excursion	2003 - 2004	3C3T-10300-AA 3C3T-10300-AC 3C3Z-10346-AA	6G	GL551	8306
6.0L	F Super Duty	2003 - 2004	3C3T-10300-AA 3C3Z-10346-AA	6G	GL551	8306
6.0L	F Super Duty	2004-2005	3C3T-10300-AC	6G	GL551	8306
6.0L	E-Series	2003 - 2004	3C3T-10300-AA 3C3Z-10346-AA	6G	GL551	8306
6.0L	E-Series	2004 - 2005	3C3T-10300-AC	6G	GL551	8306
7.3L	F-250 & 350 And Excursion	2002 & 2003	2C3Z-10346-BB	6G	GL530 GL625	8316
7.3L	F-250 & 350 And Excursion	2002 & 2003	2C3Z-10346-CB	6G	GL531 GL626	8317
7.3L	E-350	1998 - 2003	F81U-10300-CC F81U-10300-DB	6G	GL410 GL411	7798 7797
7.3L	F-Series	1993 - 1994	F3UM-10300-AF	3G		
7.3L	E-Series	1993 - 1994	F3UU-10300-AF	3G		
7.3L	F-Series	1995	F5UU-10300-BA F5UU-10300-CA	3G Melco		
7.3L	E-Series	1995	F5UU-10300-BA F5UU-10300-CA	3G Melco		
7.3L	F-Series	1996 - 1998	F5UU-10300-EA F5UU-10300-CA	3G Melco		
7.3L	E-Series	1996 - 1998	F5UU-10300-EA F5UU-10300-CA	3G Melco		
7.3L	E and F ambulance	1995 - 1998	F5UU-10300-CA	Melco		
7.3L	F-Series ambulance	1998 - 2000	F81U-10300-EB F81U-10300-GA	6G		
7.3L	E-Series ambulance	1998.5 - 2000	F81U-10300-DC F81U-10300-CC	6G		
7.3L	F-Series ambulance	2001	F81U-10300-ED F81U-10300-GC	6G		
7.3L	E-Series ambulance	2001-2003	F81U-10300-DE F81U-10300-CE	6G		
7.3L	F-Series ambulance	2002	23CU-10300-BB 23CU-10300-CB	6G		
6.0L	F-Series ambulance	2003	3C3T-10300-BB	6G		
6.0L	F-Series ambulance	2004	4C3T-10300-BA	6G		
6.0L	E-Series ambulance	2004	4C3T-10300-BA	6G		

The above part numbers are verified O.E numbers released by Ford on vehicles. These part numbers were not released as a part only for aftermarket. This list has been compiled to support T mount Diesel applications for the AV160T 230 amp development program. All information has been verified. If a cell is open this information has not been confirmed. If any bench marking is completed these variants MUST be utilized - deviation from this would risk fitment issues and aftermarket sales.

Prestolite Application Engineering written approvals required for warranty coverage.

Diesel	Vehicle	Year Models	O.E Alternator #	Type	Motorcraft Alternator #	Lester #
6.0L	F-Series ambulance	2005	5C3T-10300-BB	6G		
6.0L	E-Series ambulance	2005	4C3T-10300-BB	6G		
6.0L	F-Series ambulance	2006	6C3T-10300-BA	6G		
6.0L	E-Series ambulance	2006-2007	6C2T-10300-DA	6G		
6.0L	F-Series ambulance	2007	7C3T-10300-BB	6G		
6.4L	F-Series Super Duty base model	2008			Denso SC1	
6.4L	F-Series Super Duty upgrade	2008			Denso SC5	
6.4L	F-Series Super Duty dual alt	2008			Denso SC5	
7.3L	E-Series	1995-2003	F5UU-10300-BA F6UU-10300-EA F6UU-10300-EB	3G	GL504RM	7768
7.3L	F Series	1995-1997	F5UU-10300-BA F6UU-10300-EA F6UU-10300-EB	3G	GL504RM GL381 GL504RM	7768
7.3L	E-Ambulance Package	1999-2003	F81U-10300-DB F81U-10300-DC F81U-10300-DD F81U-10300-DE F81Z-10346-DA	6G	GL411	7797
7.3L	E-Ambulance Package	1999-2003	F81U-10300-CC F81U-10300-CD F81U-10300-CE F81Z-10346-CA	6G	GL410	7798
7.3L	E- Emergency	1995-1998	F5UU-10300-CA F5UZ-10346-CA	Mitsu	GL360	12075
7.3L	Ford Excursion	2000-2003			GL551	8306

Gas	Vehicle	Year Models	O.E Alternator #	Type	Motorcraft Alternator #	Lester #
4.0L Gas	Ranger	1990-2000		3G		
5.0L Gas (N)	F-Series	1996-1993		3G		
4.2L Gas (All)	F-Series	2002-2004		3G		
4.2L Gas (OPT)	F-Series	1997-2001		3G		
4.0L Gas	Explorer	1991-2004		3G		
4.0L Gas	Sport Trac	2000-Current		3G		
5.0L Gas (All)	Explorer	1996-2001		3G		
5.8L Gas	E-Series	1993-1996		3G		
5.0L Gas	E-Series	1993-1996		3G		
4.2L Gas	E-Series	1997-2003		3G		

## A160202-3 Navistar Applications

Diesel	Vehicle	Year Models	O.E Alternator #	Type	Motorcraft Alternator #	Lester #
V-6	Ford - Navistar LCF	2005-2011	LN-AV160T2002-3			



**Leece-Neville Heavy Duty Systems**  
7585 Empire Drive  
Florence, KY 41042  
USA

(800) 354-0560 Phone  
(800) 997-6202 Fax  
www.prestolite.com